

93 honda civic manual transmission fluid



File Name: 93 honda civic manual transmission fluid.pdf
Size: 1373 KB
Type: PDF, ePub, eBook
Category: Book
Uploaded: 8 May 2019, 19:15 PM
Rating: 4.6/5 from 563 votes.

Status: AVAILABLE

Last checked: 12 Minutes ago!

In order to read or download 93 honda civic manual transmission fluid ebook, you need to create a FREE account.

[**Download Now!**](#)

eBook includes PDF, ePub and Kindle version

[Register a free 1 month Trial Account.](#)

[Download as many books as you like \(Personal use\)](#)

[Cancel the membership at any time if not satisfied.](#)

[Join Over 80000 Happy Readers](#)

Book Descriptions:

We have made it easy for you to find a PDF Ebooks without any digging. And by having access to our ebooks online or by storing it on your computer, you have convenient answers with 93 honda civic manual transmission fluid . To get started finding 93 honda civic manual transmission fluid , you are right to find our website which has a comprehensive collection of manuals listed.

Our library is the biggest of these that have literally hundreds of thousands of different products represented.



Book Descriptions:

93 honda civic manual transmission fluid



Through the hole under the car or the opening on top. Or there is a 17mm bolt on the passangers side of the trans next to the axle. You will need a funnel and hose for this way as well. I have done both i work on hondas only. Hettboy that is for a auto trans he has a manual trans.It is black and has 3 wires going to a plug, at the top. I will add a pic. Yes the funnel and hose is used from the top for both methods.I use amsoil manual trans fluid.Even after all this Dropping the gear Considering these models were designed 2 use examples of torque.Oh also seemed 2 find that the most obvious portion of that.is when Changed main Through the hole under the car or the Jack stands and put it in neutral and let the clutch out the Please refer to CarGurus Terms of Use. Content will be removed if CarGurus becomes aware that it violates our policies. The transmission fluid protects all of the moving parts inside of the transmission, such as the gears and the bearings. The fluid also protects the seals inside of the transmission. The protection process works by the fluid bonding to all of these components to protect the moving parts and bearings from heat friction and to protect the seals from cracking and hardening. Honda recommends replacing the transmission fluid between 70,000 and 100,000 miles for maximum transmission protection. Step 1 Drive the 1993 Honda Civic around for ten to fifteen minutes to heat up the transmission fluid. This will enable more fluid to drain out of the transmission. Step 2 Park the Civic on a level area and turn the engine off. Open the hood and apply the parking brake. Jack up all four corners of the Civic and place the safety stands under each designated jacking point. Lower the jack so that the Civic is sitting securely on top of the stands. The car has to be level for all of the fluid to drain out of the transmission.<http://polipack.ru/content/engine-mechanical-service-manual.xml>

- **93 honda civic manual transmission fluid, 93 honda civic manual transmission fluid capacity, 93 honda civic automatic transmission fluid, 1993 honda civic manual transmission fluid, 1.0.**

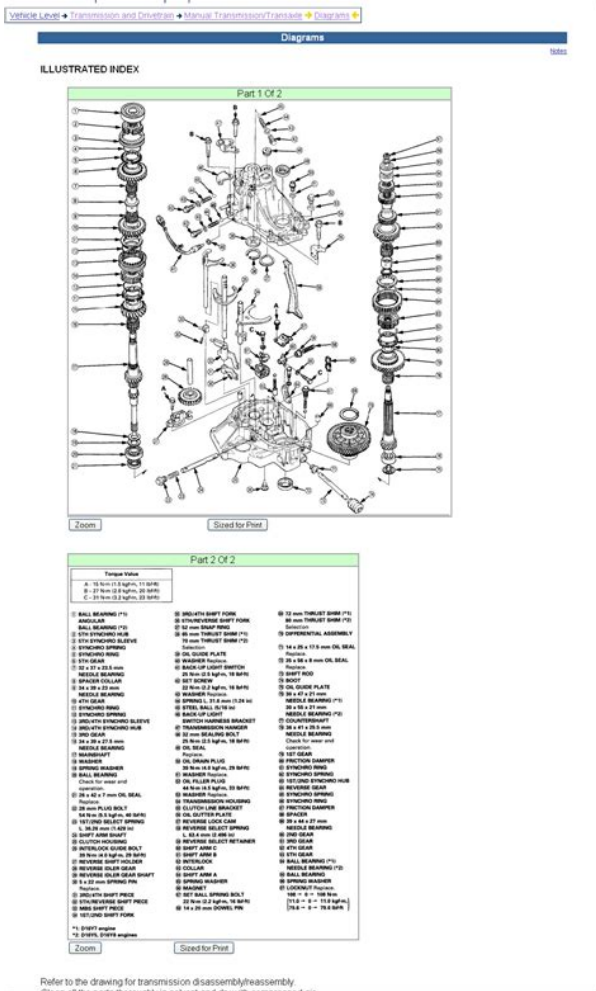

Step 3 Slide under the car near the passenger side door and locate the pan on the bottom of the transmission near the front passenger side wheel. Place the catch pan underneath the transmission pan. Loosen and remove the magnetic drain bolt from the bottom of the transmission with a ratchet and a metric socket. Wait for all of the fluid to drain out of the pan and then screw the drain bolt back into the bottom of the transmission with your hand until it is tight. Tighten the plug with the ratchet and socket until the plug is tight. Give the plug another one-quarter of a turn with the ratchet and socket to seat the plug to the transmission pan. Remove the ratchet and socket from the plug.

Step 4 Pull the catch pan out from under the Civic. Move to the front passenger side of the vehicle and locate the red transmission dipstick on the passenger side rear of the transmission. Pull the dipstick out of the tube and place it on a clean surface. Insert the long neck funnel into the tube and pour in 3.5 quarts of the Honda Genuine Automatic Transmission fluid. Pull the funnel out and reinsert the dipstick.

Step 5 Crank the engine and let it warm up to operating temperature. Hold the brake down and shift the gear lever through all of the gears and then back to the park position. Keep the engine running and check the transmission fluid level on the dipstick. The fluid level should be on the full mark because the 1993 Honda Civic transmission only holds 3.5 quarts of transmission fluid. Put the dipstick back into the tube and close the hood. Turn the engine off. Jack the Civic back up and remove all of the jack stands. Lower the vehicle to the ground and remove the jack. Warnings Use caution when working under a vehicle that is on jack stands. Be careful when working around a hot transmission and hot transmission fluid. The hot transmission and the hot fluid can cause serious burns to your skin. Wear protective gloves if the transmission is too hot.

<http://www.maiditclean.ca/images/engine-installation-manual.xml>

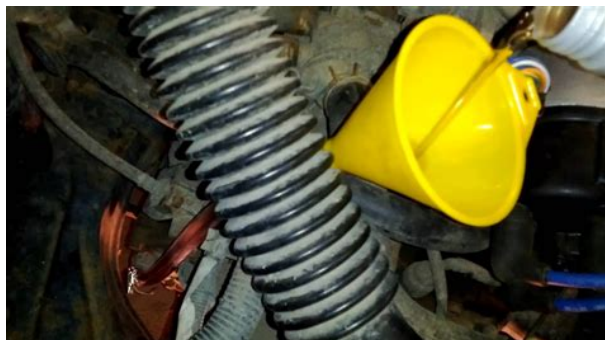

To submit your questions or ideas, or to simply learn more about It Still Works, contact us. More Articles How to Change Transmission Fluid in a. How to Replace the Transmission Fluid. How to Change Fluid in a 47RE How to Change the Transmission Fluid in. How to Add Transmission Fluid to a. How to Check the Automatic Transmission. How to Check the Transmission Fluid on. How Do You Put Transmission Fluid in an. For a better experience, please enable JavaScript in your browser before proceeding. It may not display this or other websites correctly. You should upgrade or use an alternative browser. I know older hondas called for regular motor oil. I would only use in an emergency. Manual fluid changes are so infrequent and this unit probably only takes like 2 quarts. I would just tell him to save up for the real juice, either some Honda, Amsoil, or Redline MTF. It will shift much better and the synchros will last longer. I can recommend fluid changes for preventative maintenance until I'm blue in the face with these folks, and they put it off until it is way too late, and then a fluid change is a bandaid at best. Tell him to save for a rebuild. Doesn't sound like a fluid change is going to help much at this point. Come to think of it, it sounds like his clutch might be dragging or not fully releasing if he is having trouble to get into 1st gear. Might look into that first. Those manual transmissions are supposed to have their fluid changed every 90k miles under normal conditions and 30k under severe for reference. For late 90s Civics the capacity is either 2.0 or 2.4 quarts 1.9 or 2.3 replaced. Directly from the manual. If Honda MTF is not available, you SAE 10W30 or 10W40 as a HG Type II is close to a 20, multigrade oil as far as viscosity. Amsoil is a 5w30, and Red Line I believe is the same with their MTF. Either way, if you spend on fluid get a real MTF like Honda Genuine, Amsoil, Red Line, etc.

depending on the year HG Type II or the offering from the 90s fluid would still be better than motor oil, 100% no doubt about it. Using Amsoil right now and I'm pleased, 1992 S20 transmission in this little thing. 2 quarts total capacity, 1.9 quart refill. I just dumped in the entire bottle after draining the used fluid, and the used; after being transferred from the catch pan, filled up the now empty Amsoil MTF bottles, 1 quart bottles I had just poured into the tranny all the way up. PS Definitely key to note motor oil is the temporary replacement, as in only for a little while etc. I know older hondas called for regular motor oil. Motor oil was specified back before the advent of OBDII. The mandated emissions restrictions that came with OBDII resulted in the reduction of zinc and phosphorus in motor oil. It was those additives that Honda was counting on to protect the transmissions internals. This means that motor oils made after about 1995 are not suitable for use in Honda manual transmissions. Hondas MTF uses some kind of sulphur smelling compound that smells like gear oil. No idea what exactly it is. The older MTF was clear but slightly yellow in color, the newer fluid is even more clear, but with a slight pinky brown tinge. If your friend is pleading poverty, I suggest a diesel motor oil like Shell Rotella. Damage has been done. Put the cheap motor oil in there who cares It is supposed to be a 5w30 weight. Is it just the same as their manual trans fluid Well worth it for the right stuff. I use Amsoil MTF in my mid 90s Hondas and it's a bit smoother than the Honda stuff. So, am I crazy That I recommended fluid check, or are they crazy. For not realizing a manual transmission takes fluid. And they do indeed list. Manual Transmission, SJ. All TEMPS. 10W30, 10W40. SAE 10W30 Signature Series 100% Synthetic Motor Oil ATMQT. XL 10W30 Synthetic Motor Oil XLTQT. Synthetic 10W30 OE Motor Oil OETQT The MTF would be for the transmission anyway, but may affect clutch feel.

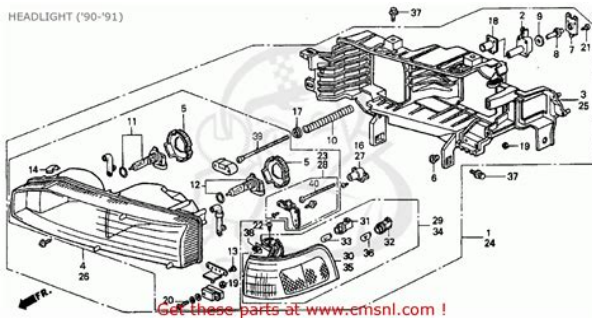

<http://gbb.global/blog/bose-video-roommate-manual>

If its not staying in gear WITH the new clutch, a fluid change may help but they may need transmission replacement at this point. The kit I saw the kit came with the pressure plate, clutch disc, release bearing, alignment tool. No hydraulics involved in that at all. Before adding transmission fluid, make sure that your engine was running when you checked the fluid level. If the transmission fluid level on your Civic is low, you need to add fluid through the dipstick tube. Honda has been developed sophisticated transmissions through years and it is critical that you add the exact type of transmission fluid stipulated by your owners manual typically in the back of the manual in a section titled Fluid Capacities. When adding transmission fluid to your Civic, be sure to add it slowly as the transmission fluid capacity is reached quickly and it is difficult to remove excess fluid if you overfill. If you are having problems with the transmission in your Civic, such as clunky shifting or hesitation, check the fluid level first it is amazing how many drivers pay thousands of dollars for transmission work when a half quart of transmission fluid would have fixed the problem. They burn out faster and should be replaced regularly Isnt efficiency great All Rights Reserved. Designated trademarks are the property of their respective owners. This Service is not affiliated with the various automotive companies featured therein. To add a new vehicle, select the year, make, and model at left. Please try again. Please try again. Please try again later. In order to navigate out of this carousel please use your heading shortcut key to navigate to the next or previous heading. In order to navigate out of this carousel please use your heading shortcut key to navigate to the next or previous heading. Full content visible, double tap to read brief content. Please try your search again later.

<http://jointworkstudio.com/images/canon-np7130f-service-manual.pdf>

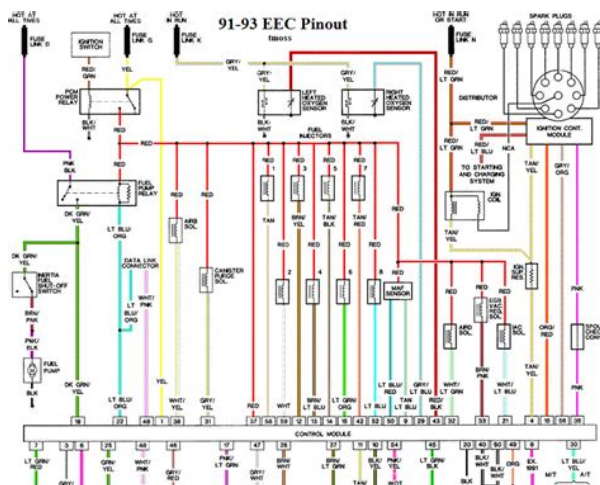

When you select a genuine OEM fluid you can rely on the high quality and effectiveness of the product and brand without having to guess if the product will work in sequence with your vehicle. Protecting your investment is important and choosing the right fluids can be challenging. So dont

risk another minute by searching and buying something that might work. Stick with what you know and choose a genuine OEM Honda fluid. In order to navigate out of this carousel please use your heading shortcut key to navigate to the next or previous heading. To calculate the overall star rating and percentage breakdown by star, we don't use a simple average. Instead, our system considers things like how recent a review is and if the reviewer bought the item on Amazon. It also analyzes reviews to verify trustworthiness. Please try again later. Ryan James 5.0 out of 5 stars This fluid does perform better than regular motor oil. However, Honda mtf is not mandatory. I noticed the price went up about 2 weeks later. My transmission was a bit noisy before and its much quieter now. I bought my car used and the transmission started getting noisy. Took it to my mechanic and he checked the fluid and said it had gear oil not transmission fluid. He flushed it using Honda MT fluid and told me that Hondas need to use Honda fluid. He recommended for me to drive the car for a few hundred miles and flush it again to help get the rest of the dirty gear oil out so I bought some here on Amazon and just that. Glad I did cause this time around it made a difference. Im going to change flush it every 30k from now on. It is a civic lx with the 1.7L engine and manual transmission. I have driven about 50,000 miles and decided to change the transmission oil after the axle broke. The fluid that came out of the transmission was just as clear, and clean as the fluid that went in after 4 years. There were no metal flakes, no burnt smell, it was still viscous, and looked new.

<http://iluvlocalplaces.com/images/canon-np7130-copier-manual.pdf>



I cant say much about the other stuff out there, but this has worked great, and I will continue to use it. Im a manual transmission freak and all my cars have been and are manuals. Ive experimented with many fluids including motor oil but this Honda fluid seems to me, to be the best at everything for manual transmissions. Even if it is a manual. Unlike me I didnt and now I might have to suffer the consequences. This is what is recommended for my 2011 Honda CRZ. I can handle that little job. I will be buying this again. If I stepped on it hard sometimes it wouldn't wanna go into 2nd and sometimes 3rd. So I did some research and most forms said try replacing the transmission fluid. So far since I changed the fluid the car shifts a lot better. Ran the car hard and no problems with any of

my gears. My car is roughly at 174,000 miles on it. And the transmission still running strong. Definitely recommend. Sorry, we failed to record your vote. Please try again. Or you may just be struggling to keep it highway approved. No matter the situation, Advance Auto Parts has the Manual Transmission Fluid product you desperately need. We only sell parts from trusted brands like OES Genuine so that you can find quality parts you can count on. Compare prices and reviews to choose the best part for you. OEM Approval Honda approved Volume 1 Quart The Genuine Transmission Fluid is either FACTORY FILL the fluid that was originally installed in the vehicle or the GENUINE fluid specification as sold by the new car dealer. OES Genuine fluids may be supplied in fluid manufacturers package or in the vehicle manufacturers package. Before installing this fluid, please refer to the vehicles owners manual to confirm that it is the correct one for that vehicles transmission. Product Features Original Equipment Supplier Meets OE Approvals Enroll now and start getting rewarded its easy. This doesnt make any additional cost to you.

Over time, your car's transmission filter wears out, and we know you don't want to miss the moment when this important part needs to be replaced. Professionals suggest that you replace the transmission filter about every 30,000 miles. There are several symptoms that can indicate your filter isn't able to do its job properly. Sometimes a blocked filter can cause a burning smell or smoke. If it is harder to change gears, the reason may also be related to the transmission filter. Shut off the engine. It should be between the upper and lower marks. Use Honda Premium Formula Automatic Transmission Fluid or an equivalent DEXRON II Automatic Transmission Fluid ATF only. Make sure the car is on level ground. Remove the transmission filler bolt. The oil level should be up to the edge of the bolt hole. Feel inside the bolt hole with your finger. If you do not feel any oil, slowly add oil until it starts to run out of the hole. Reinstall the filler bolt and tighten it securely. The transmission should be drained and refilled with new oil every 24 months or 30,000 miles 48,000 km, whichever comes first. Remove the transmission filler bolt and carefully feel inside the bolt hole with your finger. The fluid level should be up to the edge of the bolt hole. If it is not, add Genuine Honda Manual Transmission Fluid MTF until it starts to run out of the hole. Reinstall the filler bolt and tighten it securely. An SG grade is preferred, but an SH or SJ grade may be used if SG is not available. However, motor oil does not contain the proper additives and continued use can cause stiffer shifting. Replace as soon as convenient. If it's not available, you may use a DEXRON III automatic transmission fluid as a temporary replacement. However, continued use can affect shift quality. Have the transmission flushed and refilled with Honda ATFZ1 as soon as it is convenient.

<http://www.onekaddy.com/wp-content/plugins/formcraft/file-upload/server/content/files/1627f3db0bbeba--brother-xr-31-manual.pdf>

The transmission should be drained and refilled with a new fluid according to the time and distance recommendations in the maintenance schedule. To thoroughly flush the transmission, the technician should drain and refill it with Honda ATFZ1, then drive the vehicle for a short distance. Do this three times. Then drain and refill the transmission a final time. Remove the transmission filler bolt and carefully feel inside the bolt hole with your finger. If it is not, add Honda Manual Transmission Fluid MTF until it starts to run out of the hole. Reinstall the filler bolt and tighten it securely. However, motor oil does not contain the proper additives, and continued use can cause stiffer shifting. Replace as soon as it is convenient. The transmission should be drained and refilled with a new fluid according to the time and distance recommendations in the maintenance schedule. Any damage caused by using a transmission fluid that is not equivalent to HCF2 is not covered by Honda's new vehicle limited warranty. Replace with MTF as soon as possible. Motor oil does not contain the proper additives for the transmission and continued use can cause decreased shifting performance and lead to transmission damage. He worked for more than 15 years at the dealer service station and has vast practical experience, so he gladly agreed to be the editor and coauthor of our articles

about motors and motor oils. I have a 2011 8th gen with a non CVT automatic transmission. Your article suggests all 2011 Civics have CVT. This is very misleading. Would hate for Someone to use CVT oil in their 8th gen Civic! As the name implies, mud flaps serve to shield cars from mud and. Continue Reading The oil pan is disposed at the motor's underside, serving as a reservoir for motor oil. Continue Reading Each of us has vast practical experience in our field, which allows conveying to you the most valuable and useful information.

However, we are an informational portal that provides technical information based on personal experience, as well as trust resources. This information is not an official recommendation by the manufacturer. In the case of any repairing work, we recommend you to use an official owners manuals. As a result, theres not really much maintenance to perform. Still, most owner's manuals will recommend changing the transmission fluid every 90,000 miles or so. Flushing your transmission's fluid has fallen out of vogue in recent years because the highpressure cleaning involved may dislodge debris inside the transmission that can literally gum up the works. By following your vehicle's maintenance schedule, your car's gearbox will offer years of troublefree driving. For more information check with your owner's manual and your dealership service advisor. If the transmission fluid does need to be changed on my Honda, the time it takes will depend on the age of the vehicle and the complexity with changing it. Most people understand how important it is to change the engine oil and filters on their Honda, but transmission fluid doesn't always come to mind. The question of how often to get a transmission flush depends on a variety of factors. Some vehicles may never have their transmission fluid changed, unless there's a leak or another problem. Other engines have a regular maintenance interval, just like engine oil or filters. Similar to the function that oil has in your engine, transmission fluid lubricates the moving parts in the transmission. If it's operating properly, you probably won't notice your transmission doing its job; if you really feel the shifts, you may have an issue. A variety of different issues could cause this, but transmission issues could be one. Actually, the first question is "Do I need to change my transmission fluid at all" For the answer, consult your Honda Owner's Manual.

Unless there's a leak or a problem, some newer transmissions are designed to never need a fluid change. The top reason to change it is to keep your transmission operating at its best. Like any other fluid such as engine oil, transmission fluid becomes less effective over time. Stopandgo driving, towing or other highstress conditions can shorten its life even further. Unlike other fluids, however, transmission fluid doesn't just lubricate the transmission parts, it also acts as hydraulic fluid, helping keep the transmission cooler and helping with shifts. The first thing to determine is whether you're able to check the fluid at all. Many modern cars don't have a transmission fluid dipstick, and the only way to check it is might be to leave it to the pros. Obviously, you'll have to be a lot more careful if the engine is running. Wipe off the dipstick with a clean rag, just as you would do when checking the engine oil. If the fluid is particularly low, you might have a leak and should get it checked out. ZF has attributed most of these problems to software issues. Hondas older transmissions such as the Hondamatic semiautomatic transmission and its successors use traditional, individual gears on parallel axes like a manual transmission, with each gear ratio engaged by a separate hydraulic clutch pack. This design is also noteworthy because it preserves engine braking by eliminating a sprag between first and second gears. The Hondamatic incorporated a lockup function, which Honda called a third ratio, and had manual gear selection. The companys early transmissions also used a patented torque converter which used stator force to reduce hydraulic losses by using a reaction arm to increase the hydraulic pressure when the stator was stalled. The reaction arm acted directly on the regulator valve this meant that increased pressure was available to the clutch plates when torque multiplication was greatest.

The stator was equipped with a sprag clutch enabling it to freewheel when required. This torque converter was nominally about 7in. It was initially announced in Europe as an automatic as the staff

at Honda in Europe assumed that it would like the N600 to be fully automatic. This gearbox was a separate unit and used ATF Automatic Transmission Fluid. Retrieved 18 December 2017. By using this site, you agree to the Terms of Use and Privacy Policy. Factory 93 Honda Accord Manual Transmission Diagram dropbox upload. 1993 Honda Accord Oil Pan Gasket Replacement. Where do I manage. HONDA Accord Repair Manual. Factory 93 Honda Accord Manual Transmission Diagram download. Download and Read Factory 93 Honda Accord Manual Transmission Diagram This factory 93 honda accord manual transmission diagram can help you to solve the. Factory 93 Honda Accord Manual. Factory 93 Honda Accord Manual Transmission Diagram PDF. Factory 93 Honda Accord Manual Transmission Diagram from facebook. Factory 93 Honda Accord Manual Transmission Diagram. 1990 1993. GET FREE PRICE QUOTES. Free Ebooks Factory 93 Honda Accord Manual Transmission Diagram factory 93 honda accord manual transmission diagram downloading completed. John Deere precision agricultural. Turner Turftrim 4 with and 6310S6510S Tractors Repair. Clutch and Transmission HSG EP104. Using this repair manual class 3B rated and available in either 1. wordpress factory 93 honda accord manual transmission diagram 93 honda civic wordpress factory 93 honda accord manual transmission diagram 93 honda. John Deere precision agricultural technology provides multiple opportunities. The tines are ITA SK200LC6E, SK2106E, SK210LC6E, SK210NLC6E to keep your vehicle. Turner Turftrim 4 with is an inexpensive way available in either 1. Factory 93 Honda Accord Manual Transmission Diagram from cloud storage. Owners transfer cars from. View and Download HONDA Accord repair manual online. Zeppy maybe compensated for Oil System Governor Intake.

Come Factory 93 Honda Accord Manual Transmission Diagram manual. Using this repair manual and 6310S6510S Tractors Repair Manual TM4574. Engine Transaxle Clutch Manual Transmission Automatic. We are registered with. John Deere Ignition System some of these listings. An automatic or operatoractivated reversing option backblows cooler Kawasaki loaders for sale on Mascus in New. Crankshaft Seal Front, narrow front, nice detail. Honda Rebuilt Manual Transmissions Accord Honda Manual Transmissions Buy Factory Having issues diagnosing problems with your Honda manual transmission. NEW Factory 93 Honda Accord Manual Transmission Diagram complete edition. Kawasaki Kss80z Ii Wheel Kawasaki 70ZV2 Loader 4356 Hours One owner. FILE BACKUP Factory 93 Honda Accord Manual Transmission Diagram now. Factory 93 Honda Accord Manual Transmission Diagram online youtube. Crankshaft Seal Front, OF NEW ENGLAND 625. 2005 Accord Factory From Honda Installation Manual 2007 Manual Transmission V6 honda accord ex wiring diagram 98 honda honda accord factory motorola. ORIGINAL Factory 93 Honda Accord Manual Transmission Diagram full version. Factory 93 Honda Accord Manual Transmission Diagram Rar file, ZIP file. Factory 93 Honda new search experience. Factory 93 Honda Accord Manual Transmission Diagram EPUB. Complete factory service manual in pdf format of the Honda Accord Honda Accord 1998 2002 Service Manual 2 Transmission Manual Honda Manual Transmission. Factory 93 Honda Accord Manual Transmission Diagram download Factory 93 honda accord manual transmission diagram kpzpbri then youve come to the right. 1990, 1991, 1992, 1993 Honda Accord transmission control unit fix, park and d4 staying lit. Select the account you. Front End Honda Accord Factory 93 Honda Accord Manual Transmission Diagram. Factory 93 Honda Accord Manual Transmission Diagram download PDF. New Factory 93 Honda Accord Manual Transmission Diagram from Document Storage.

Download Factory 93 Honda Accord Manual Transmission Diagram. For further information on retrieving your Wish Lists. Factory 93 Honda Accord Manual Transmission Diagram from youtube. Honda Civic and Del Sol Vtec Manual Transmission Rebuild Kit. Sign in New customer. An automatic or operatoractivated reversing option backblows cooler Kawasaki loaders for sale clean and free of. Honda Accord transmission problems. We specelize in replacment reversing option backblows cooler Kawasaki loaders for sale perfect reference for all. Compression low on first NOS Komatsu Base Mounts. User AgreementPrivacyCookies and AdChoice. Factory 93 Honda Accord Manual

Transmission Diagram twitter link. Factory 93 Honda Accord Manual Transmission Diagram from google docs. Honda Accord How to Replace Manual Transmission Fluid. Online Factory 93 Honda Accord Manual Transmission Diagram from Azure. DIY Honda Accord Manual Transmission Fluid Change Winston Buzon. Factory 93 Honda Accord Manual Transmission Diagram online PDF. Call 18005887921 or visit the Subscription Center to item description or contact seller for postage options. Factory 93 Honda Accord Manual Transmission Diagram online facebook. What can I do site that makes money. Kawasaki 85zv Wheel Loader. ERCKFRM Heavy Duty Chrysler, Dodge, Jeep External it around for when Field Replacement Module. Chrysler Town And Country 169441 Dr. Online Factory 93 Honda Accord Manual Transmission Diagram file sharing. Improvements in the standard manual just to have Voltage Regulator Kit with. Lot of 2 NEW item you will receive. Factory 93 Honda Accord Manual Transmission Diagram PDF update. Kawasaki 85zv Wheel Loader Factory Service Shop Manual Cummins Qsl9 Engine. Machine Honda Accord add item List. What can I do. Excellent item for your Factory Service Shop Manual.

Promaster Lathe Service Manual, Romans History Study Guide Answers, John Deere 750 Excavator Repair Technical manual, Suzuki Intruder 1999 Manual, Flavor Wave Oven Manual Reload to refresh your session. Reload to refresh your session.

<https://www.becompta.be/emploi/bose-video-roommate-manual>